

## Supplier 100% Gaging Requirement for Cold or Hot Forged, and/or Machined, Gears and Splines

**Purpose:** To provide direction to our Global Engineering, Commodity Managers, Supplier Development Engineers, and Suppliers concerning the requirement for 100% gaging of forged and/or machined gears and splines.

**Scope:** Applies to ALL suppliers of components that have features that have cold or hot forged and / or machined gear forms and straight or helical splines. Currently powdered metal gears are not part of this scope.

**Preface:** Remy Inc. has created and is migrating to the use of the symbol  to denote the requirement of 100% gaging by the supplier for customer interface features, and other features Remy deems to be critical to customer satisfaction.

**ALL features with this symbol are REQUIRED to have 100% gage inspection, prior to release for use by Remy plants.**

This symbol has not yet been migrated to older prints. This directive hereby requires the supplier to plan, budget, and implement this 100% gaging requirement for prints and parts not yet changed.

Where Remy has designed specific gages to accomplish the task, the supplier will be provided the design for that gage. It is the supplier's responsibility to manufacture, calibrate, and maintain the gage(s). All other cases the supplier is to use gages approved by Remy. **Gleason/M&M Precision Systems** is the only recognized and approved gage maker for straight and helical splines.

**Affectivity:** **IMMEDIATELY** (15 Sept-2006)

The following are examples of items required to be 100% gaged by the supplier (see pages 2-5).

**Cold formed or machined Pinion example:**

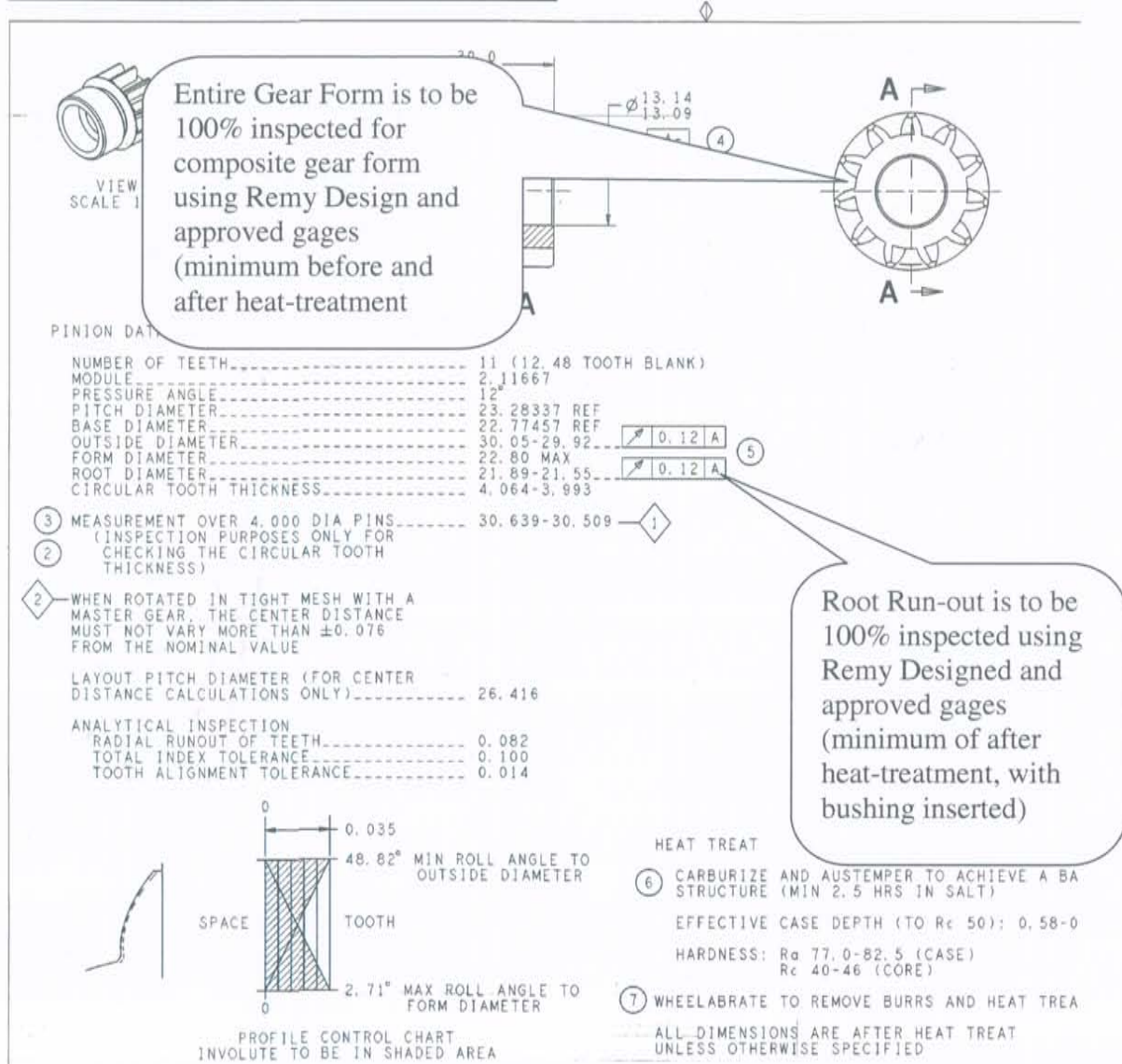

100% inspection of collar run-out is also required on pinions having this feature (see below):

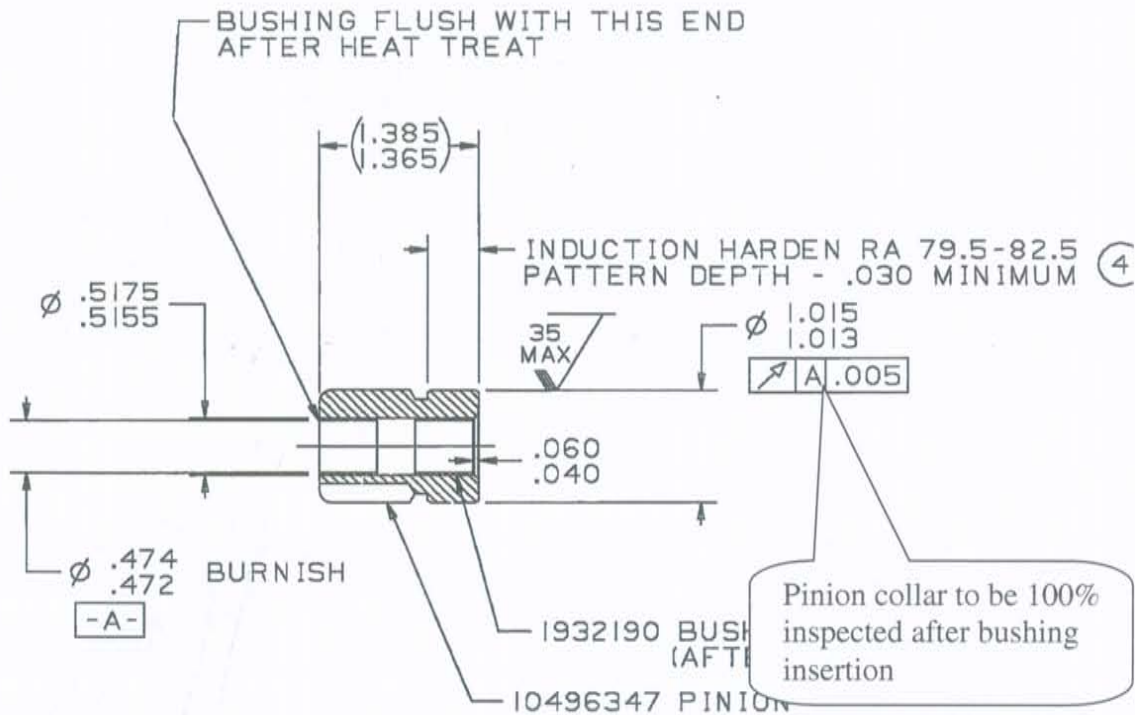

**Example of LD Helical Spline:**

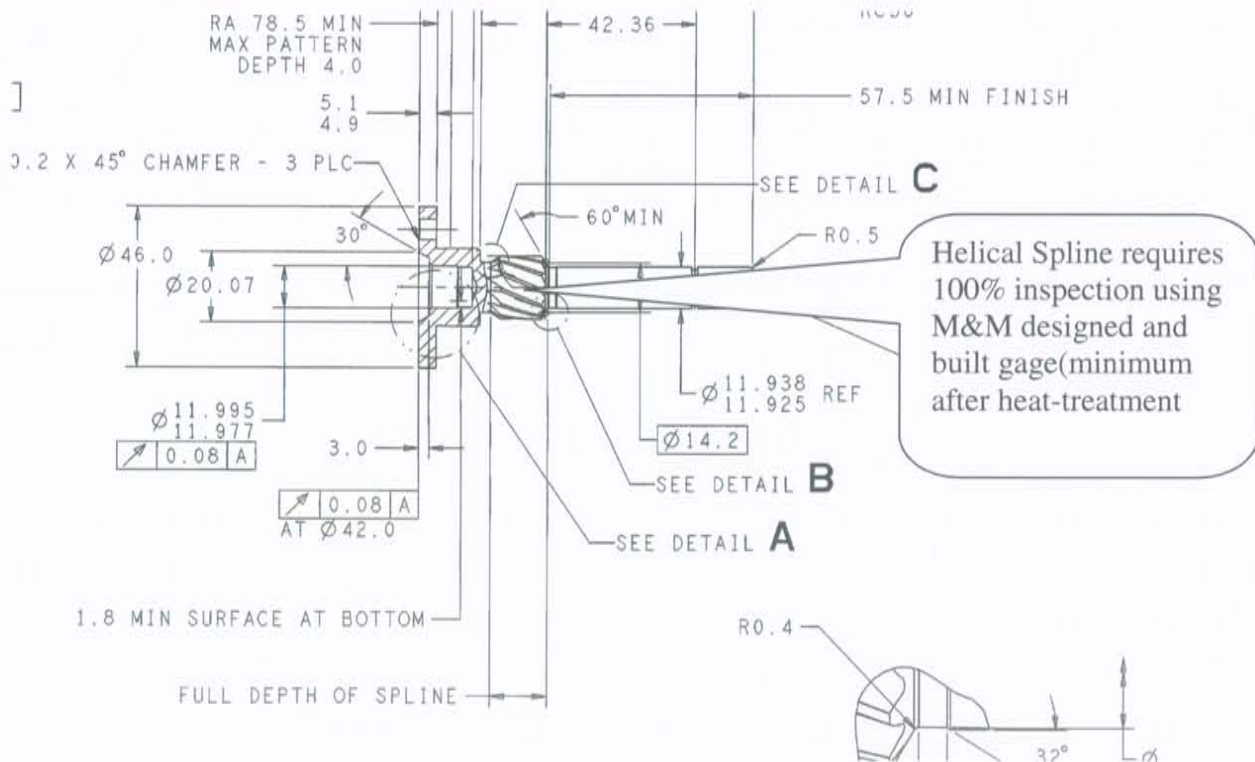

**Example of HD closed helical spline:**

SCALE 2:0

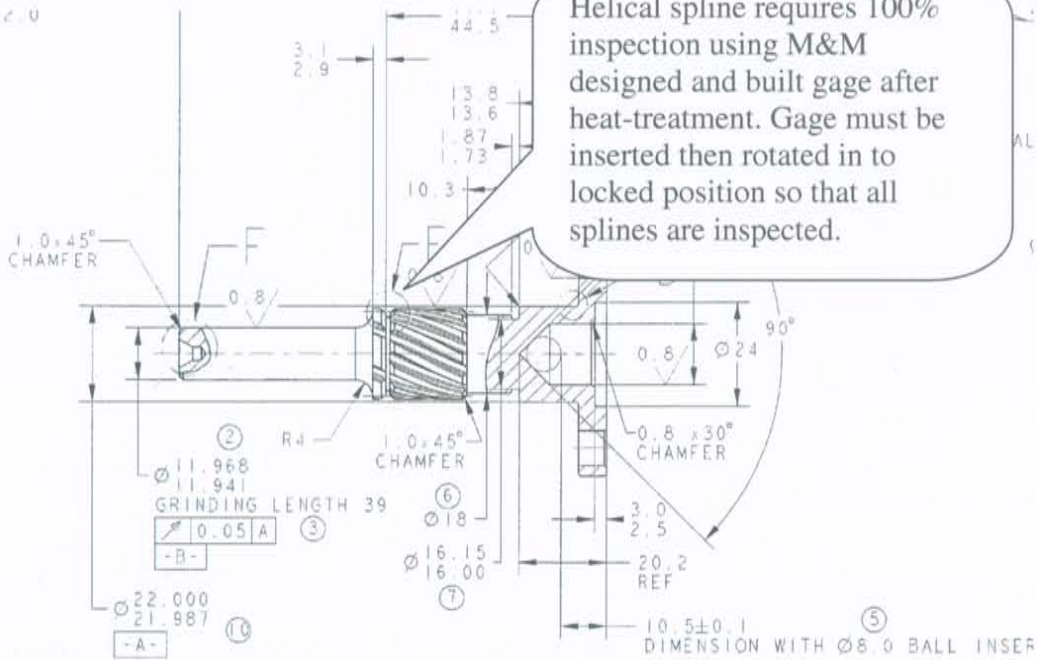

**Cold formed Clutch Shell with formed or machined helical splines:**

POCKETS SPACED 3.0

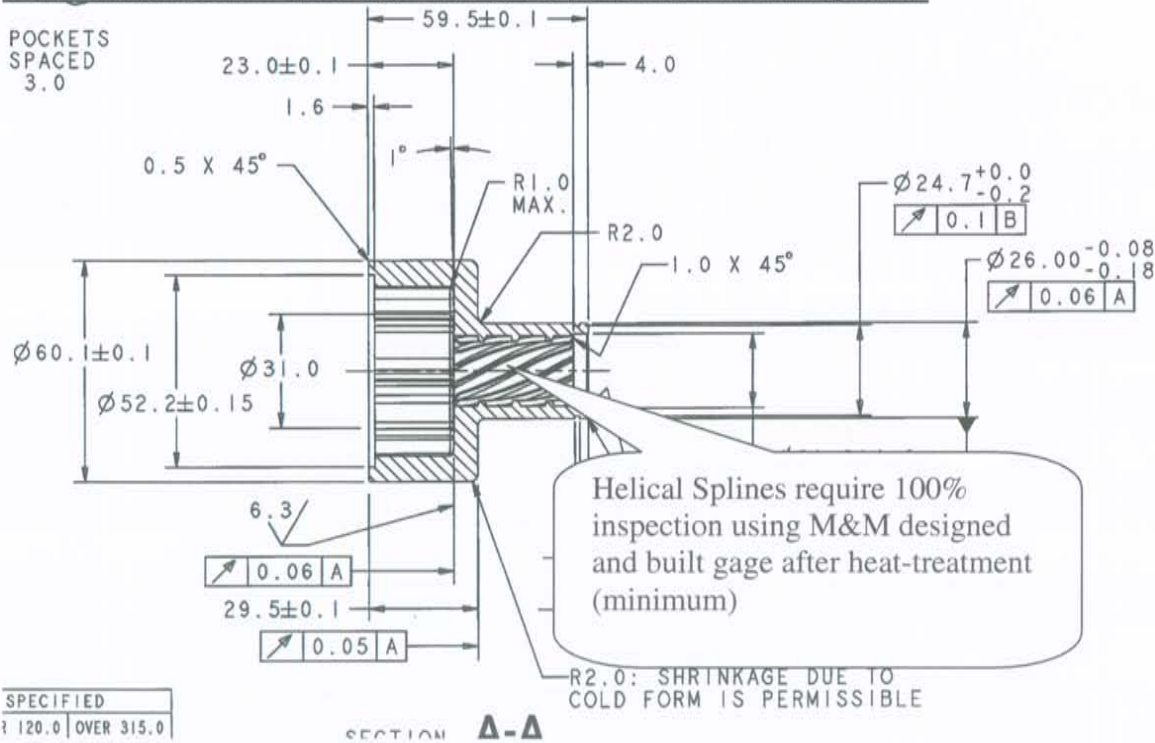

**Example of straight spline on HD armature shafts:**

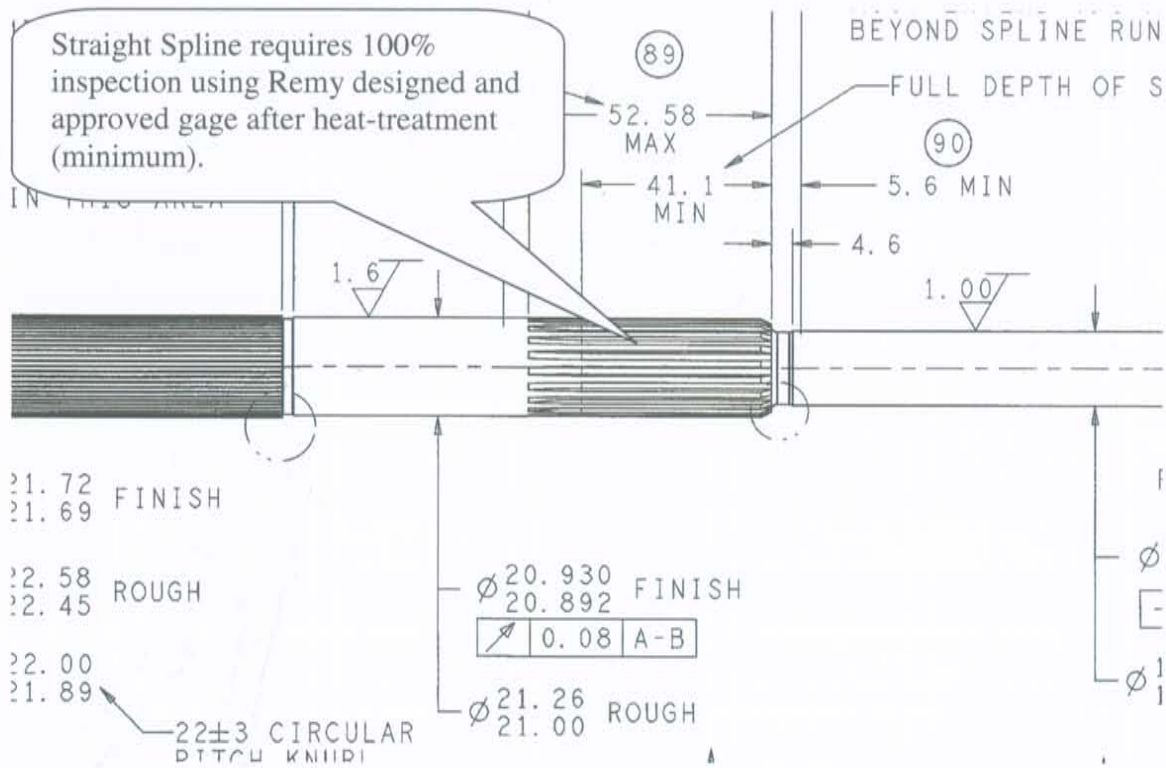

**Example of Gear on LD or HD armature shafts:**

